

RV111 may be fitted instead of \*RV109 to convert the output power adjustment to internal access only.

The circuitry for the break-off D-range PCB is shown on the control section circuit diagram.

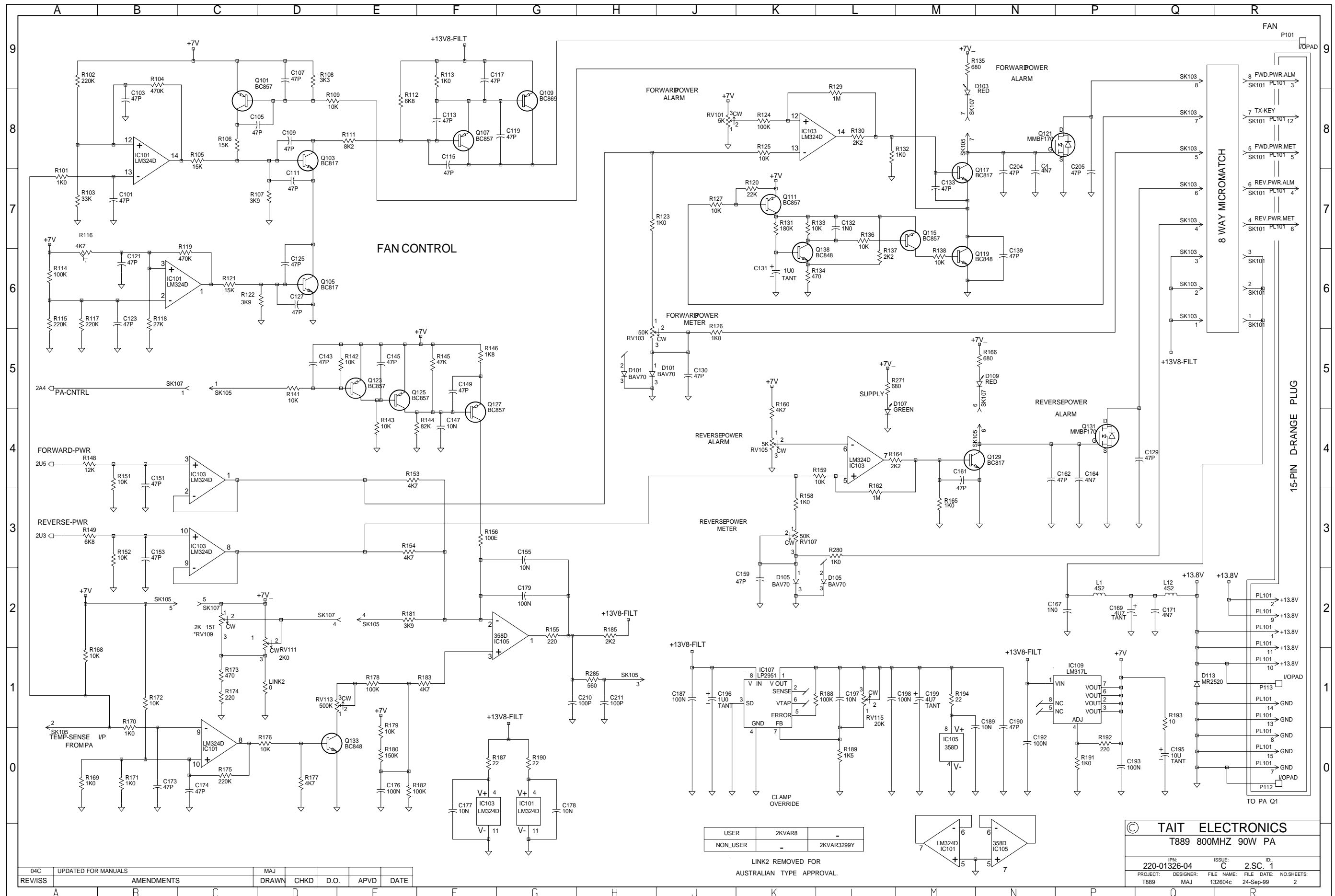

USER	2KVAR8	-
NON_USER	-	2KVAR3299Y

LINK2 REMOVED FOR AUSTRALIAN TYPE APPROVAL.

© TAIT ELECTRONICS  
T889 800MHZ 90W PA

IPN	220-01326-04	ISSUE	C	2	SC	1			
PROJECT	T889	DESIGNER	MAJ	FILE NAME	132604c	FILE DATE	24-Sep-99	NO. SHEETS	2

04C	UPDATED FOR MANUALS	MAJ				
REV/ISS	AMENDMENTS	DRAWN	CHKD	D.O.	APVD	DATE

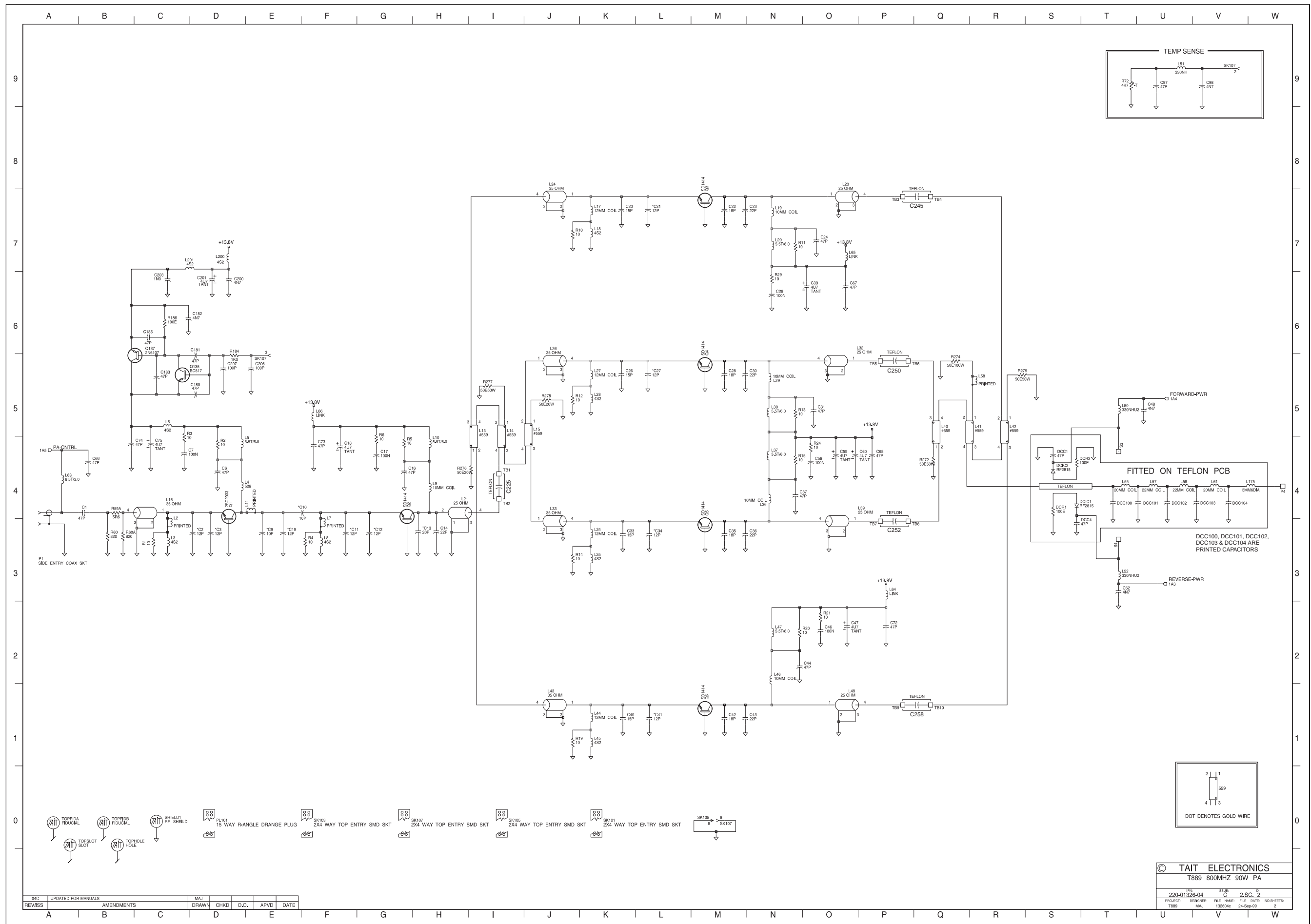

REV	DESCRIPTION	MAJ	CHKD	D.O.	APVD	DATE
001	UPDATED FOR MANUALS					
002	AMENDMENTS					

© TAIT ELECTRONICS	
T889 800MHZ 90W PA	
REV: C	ISSUE: 2
PROJECT: T889	DESIGNER: MAJ
FILE NAME: 132004c	FILE DATE: 24-Sep-99
NO. SHEETS: 2	SHEET NO: 2